

# Low Temperature Geothermal Resource Assessment for Membrane Distillation Desalination in the United States

Sertaç Akar and Craig Turchi

National Renewable Energy Laboratory, Golden, CO  
[craig.turchi@nrel.gov](mailto:craig.turchi@nrel.gov) • [sertac.akar@nrel.gov](mailto:sertac.akar@nrel.gov)

## Keywords

*Low temperature, direct-use, desalination, membrane distillation*

## ABSTRACT

Substantial drought and declines in potable groundwater in the United States over the last decade have decreased the availability of fresh water. Desalination of saline water such as brackish surface or groundwater, seawater, brines co-produced from oil and gas operations, industrial wastewater, blow-down water from power plant cooling towers, and agriculture drainage water can reduce the volume of water that requires disposal while providing a source of high-quality fresh water for industrial or commercial use. Membrane distillation (MD) is a developing technology that uses low-temperature thermal energy for desalination. Geothermal heat can be an ideal thermal-energy source for MD desalination technology, with a target average cost of \$1/m<sup>3</sup> to \$2/m<sup>3</sup> for desalinated water depending on the cost of heat. Three different cases were analyzed to estimate levelized cost of heat (LCOH) for integration of MD desalination technology with low-grade geothermal heat: (1) residual heat from injection brine at a geothermal power plant, (2) heat from existing under-utilized low-temperature wells, and (3) drilling new wells for low-temperature resources. The Central and Western United States have important low-temperature (<90°C) geothermal resource potential with wide geographic distribution, but these resources are highly under-utilized because they are inefficient for power production. According to the U.S. Geological Survey, there are 1,075 identified low-temperature hydrothermal systems, 55 low-temperature sedimentary systems and 248 identified medium- to high-temperature geothermal systems in the United States. The estimated total beneficial heat potential from identified low-temperature hydrothermal geothermal systems and residual beneficial heat from medium- to high-temperature systems is estimated as 36,300 MW<sub>th</sub>, which could theoretically produce 1.4 to 7 million m<sup>3</sup>/day of potable water, depending on desalination efficiency.

## 1. Introduction

Substantial declines in potable groundwater have been observed across the United States in the past decade (Famiglietti and Rodell, 2013). Along with water conservation measures, desalination is gaining attention throughout the United States as an alternative fresh-water source to hedge against future drought and water shortages due to population growth, weather patterns, and climate change. In the West, many of the aquifers experiencing the highest declines are situated in areas where geothermal resources coexist (Figure 1).

U.S. geothermal resources are primarily located in the western states and are often categorized into high-temperature and low-temperature resources. Typically, low-temperature geothermal resources are less than 90°C and may be applied for small-scale power generation, but are more readily useful for direct-use applications. A potentially useful application of the geothermal energy from low-temperature resources or rejected heat from high-temperature geothermal power plants is thermal desalination of impaired waters. Desalination of impaired waters can reduce the volume of water that requires disposal while providing a source of high-quality fresh water for industrial or commercial use. A viable geothermal desali-

nation application must have brackish source water that can be processed via pretreatment and desalination processes to create beneficial product water at a low cost. Potential source waters include brackish surface or groundwater, seawater, brines co-produced from oil and gas operations, industrial wastewater, blow-down water from water-cooled power plants, and agriculture drainage water. In some instances the geothermal brine itself could be used as the source water.

### 1.1 Review of Membrane Distillation Technology

Multistage flash (MSF), multi-effect distillation (MED), reverse osmosis (RO) and membrane distillation (MD) are the top four desalination technologies in terms of worldwide installed capacity (Ziolkowska, 2015). These technologies consume electric energy and/or thermal energy as a primary operating cost. RO is an all-electric technology, whereas MSF, MED and MD are primarily thermal, with some electric demand for pumping and controls. For situations with available low-temperature geothermal energy, the best integration approaches utilize thermal-desalination technologies such as MED or MD, rather than electric-driven technologies such as RO. The examination of different desalination technologies led to the selection of MD for pairing with geothermal energy (Turchi et al., 2015). MD evaporates water through hydrophobic membranes at near-ambient pressure and temperatures less than 100°C (Kesieme et al., 2013). The technology is modular like RO, but the equipment costs are lower. The thermal energy demands of MD are higher than MED but this is offset by an ability to run at lower temperatures and a low capital cost. Consequently, a geothermal-MD system could offer a low capital cost and if paired with low-cost geothermal energy, a low operating cost. The MD process uses the partial vapor-pressure difference across the hydrophobic microporous membranes. Water vapor passes through the membrane from the hot-brine side to the cool-permeate side. The basic components of an MD system are shown in Figure 2. Systems can be configured for a single pass (as shown) or with source-water recirculation to achieve high recovery.

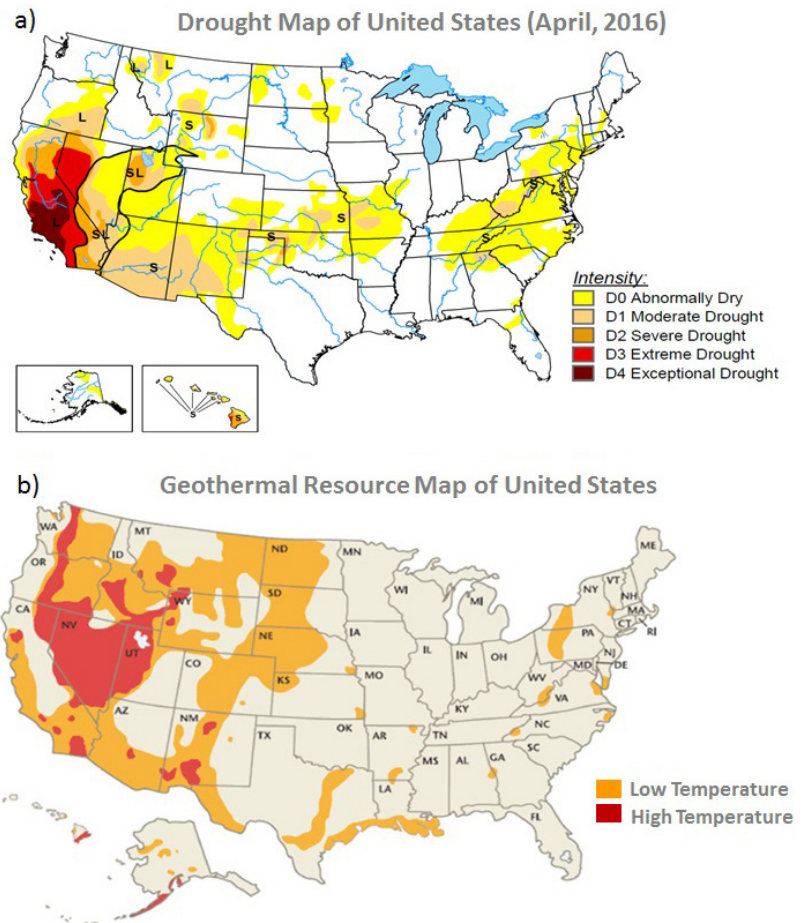

Figure 1. a) Drought map of United States in April, 2016 (NDMC, 2016) S = short-term, typically less than 6 months, L = long-term, typically greater than 6 months, b) Extent of low-temperature <100° C (orange color) geothermal resources (not including Enhanced Geothermal Systems potential) in United States (Data: OIT-GHC, 1996).

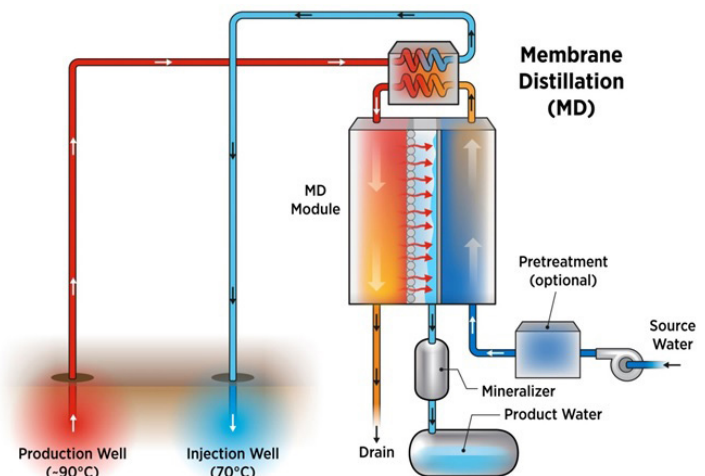

Figure 2. Typical schematic of a basic single-pass MD desalination system with geothermal energy source.

## 2. Low-Temperature Geothermal Resources

Low-temperature geothermal resources occur in two main categories: 1) convection-dominated hydrothermal resources including isolated and delineated-area geothermal systems, and 2) conduction-dominated sedimentary systems and coastal plains. The USGS defines low-temperature geothermal resources as geothermal systems with a reservoir

temperature less than 90°C, and a minimum temperature defined as 10°C above the mean annual air temperature at the surface and increasing by 25°C/km with depth (Reed, 1983). The USGS has also developed a concept for beneficial heat based on an empirical relation between temperature drop within production time and the initial reservoir temperature (see section 2.3).

## 2.1 Convection-Dominated Hydrothermal Systems

In convection-dominated hydrothermal systems, upward circulation of water transports thermal energy to reservoirs at shallow depths or to the surface. These systems commonly occur in regions of active tectonism and above-normal heat flow.

### 2.1.1. Isolated Low-Temperature Geothermal Systems

*Isolated systems* are hydrothermal reservoirs with surface expression and thermal springs, or a well that produces thermal water. They have geologic control and commonly occur along normal faults or folded and thrust rocks. The surface evidence of geothermal reservoirs include single thermal springs, alteration zones or a well that produces thermal water. In the Western United States, thermal springs commonly occur along normal faults, whereas in the Eastern United States, thermal springs occur in regions of folded and thrust-faulted rocks (Figure 3).

### 2.2.2. Delineated-Area Low Temperature Geothermal Systems

*Delineated-area systems* are hydrothermal systems characterized by the upflow of thermal water along faults and its subsequent lateral movement into aquifers at relatively shallow depths. There may not be an associated discharge of thermal springs at the surface, and the shallow thermal aquifer may be underlain by a hotter reservoir at greater depths. Although detection of systems of this type is hampered by absence of surface manifestations, they mainly occur where thermal springs are associated with granitic plutons. They also occur where heat flow data and exploratory drilling indicate that low temperature geothermal reservoirs exist in fractured bedrock highs just below contact with the overlying less-permeable valley fill (Figure 3).

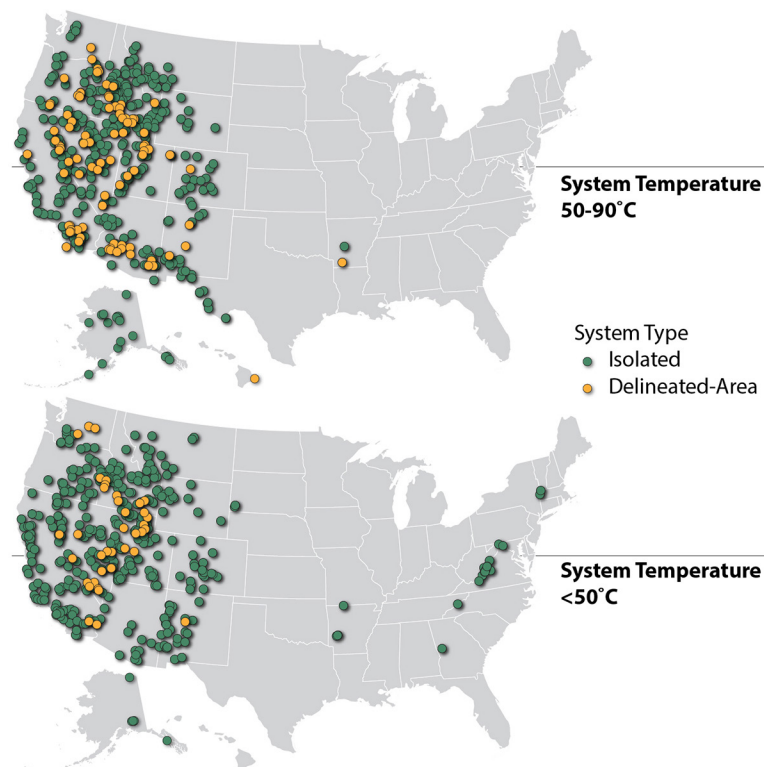
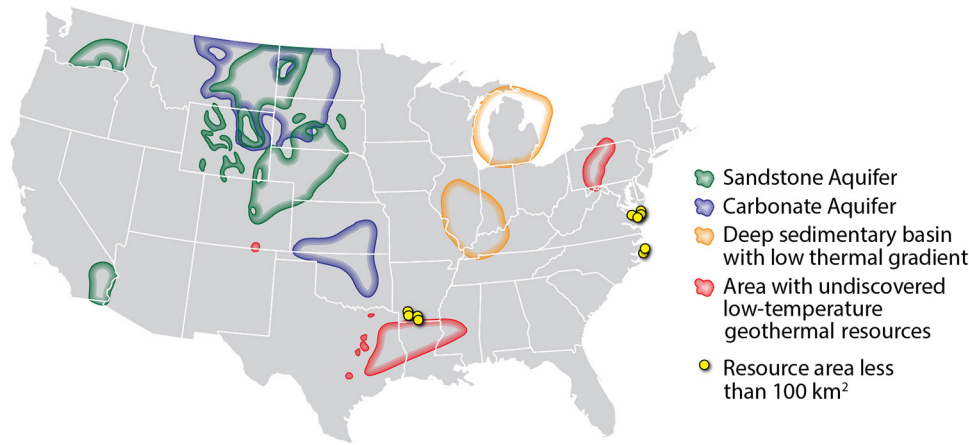

**Figure 3.** Distribution of low temperature hydrothermal system in United States; a) isolated and delineated-area systems having temperature between 50°C and 90°C, and b) having temperatures less than 50°C (Data Source: Reed, 1983).

## 2.2 Conduction-Dominated Sedimentary and Coastal Plain Systems

Sedimentary and coastal plains systems are conduction-dominated systems that do not have circulating hydrothermal fluid but have permeability and porosity within the reservoir rocks. Thus, they are different than enhanced geothermal systems (EGS), which need artificial fracturing to achieve permeability. Average reservoir depth of sedimentary systems (<2 km) is also shallower than EGS. Sedimentary systems are regionally continuous thick layers of carbonate and sandstone aquifers with relatively high temperature gradients. A typical example of a sedimentary isolated system is Powder River Basin geothermal area in Wyoming. Similarly, coastal plain systems consist of a thick sedimentary layer underlain by an intrusive body that generates elevated heat flow by radioactive decay.

The USGS has identified 43 sedimentary systems (23 sandstone aquifers, 20 carbonate aquifers) and 12 coastal plain systems (6 sandstone aquifers, 1 limestone aquifer, and 5 loose sands). These identified low-temperature (<90°C) sedimentary geothermal systems, coastal plains and areas containing undiscovered deep geothermal resources associated with sedimentary basins are mostly located in the Eastern and Central United States, as well as the Columbia River Plateau, Washington and Imperial Valley, California (Figure 4). Our analysis is limited to low-temperature sedimentary systems. Detailed information on sedimentary systems with temperatures greater than 90°C can be found at Porro et al., 2012.



**Figure 4.** Distribution of low-temperature (<90°C) sedimentary geothermal systems in United States (Modified from Muffler, 1979). [Green polygons are sandstone aquifers and blue polygons are carbonate aquifers with sandstones having reservoir temperature below 90 °C and above the minimum temperature criterion. Red polygons are areas with undiscovered resources in coastal plains with permeable unknown reservoir rocks overlain by impermeable shale formation having low temperature geothermal potential. Orange polygons are the Deep Sedimentary systems (>2 km) with low thermal gradient (<25°C) and unknown reservoir type. Yellow points represent small scale (<100 km²) coastal plain systems with low-temperature resource potential.]

### 2.3 Definition of Beneficial Heat Concept Defined by USGS

In Circular 892 “beneficial heat” is defined by the USGS as that part of the resource that is usable in a specific application; beneficial heat is a function of the temperature drop within the application system, and an empirical relation between temperature drop and reservoir temperature (Reed, 1983; Williams, 2015). The beneficial heat available from the low-temperature resource can be calculated as a fixed fraction of the wellhead thermal energy using the empirical equation given below:

$$q_{ben} = 0.6\rho C \left( \frac{ka}{a_w} \right) \cdot Q \cdot P \cdot (T_r - 25) \tag{1}$$

Where:

- $q_{ben}$  : Beneficial heat ( $MW_{th}$ )
- $Q$  : Volumetric flow
- $\rho C$  : Volumetric specific heat ( $J/cm^3 \cdot K$ )
- $k$  : Transmissivity constant (values between 0 and 1)
- $a$  : Reservoir area ( $km^2$ )
- $a_w$  : Optimum reservoir area per well ( $km^2$ )
- $P$  : Duration of production period
- $(T_r - 25^\circ C)$  : Usable temperature drop down ( $^\circ C$ )

$T_r$  represents initial reservoir temperature and the term  $(ka/a_w)$  represents the mean number of wells each reservoir can support according to the reservoir flow. The units for reporting beneficial heat are megawatts thermal ( $MW_{th}$ ) for 30 years, and the values obtained represent energy that might be used in applications at the surface. Mean resource energy for each identified thermal reservoir is calculated by assuming a recovery factor between 8% and 25% for fracture-dominated hydrothermal systems with a standard volume of  $1 km^3$  (Williams et al., 2008) and estimating the number of production wells that a reservoir with a larger than standard volume can support for 30 years with a cumulative drawdown of 152 m (Reed, 1983). The best estimate for the recovery factor for hydrothermal systems is defined as 10% (Grant, 2015). Similarly, the mean resource energy for each identified sediment-hosted reservoir is calculated by assuming a recovery factor between 10% and 25% (Williams et al., 2008).

### 2.4 Beneficial Geothermal Heat Potential By State

The USGS identified 1,075 convection dominated hydrothermal systems and 55 sedimentary systems in the United States (Reed, 1983). Total estimated resource capacity including all of the identified isolated systems, delineated systems, and sedimentary and coastal plains systems was estimated as 41,176  $MW_{th}$  in 1982 and updated to 46,500  $MW_{th}$  in 2015 (Williams et al., 2015). The share of identified low-temperature hydrothermal systems in total estimated beneficial heat is around 13,000  $MW_{th}$ . Figure 5 summarizes the beneficial heat potential from low-temperature geothermal systems in 24 states. Currently in United States, the total installed capacity of direct heat applications from low-temperature geothermal resources is only 616  $MW_{th}$  (Boyd, 2015). The applications of direct use are generally well established and include: space heating, district heating, greenhouse heating, aquaculture pond and raceway heating, agricultural drying, industrial applications, bathing, swimming pool and spa heating, and snow melting (Lund, 2012). Geographic distribution of categorized resource potential of low-temperature hydrothermal and sedimentary systems by state is presented in Figure 6.

### 3. Excess or Residual Heat from Medium- and High-Temperature Geothermal Resources

Unused heat from medium- and high-enthalpy geothermal resources can also be a potential source of heat for MD desalination. This excess and/or residual heat may come from re-injection brine from a geothermal power plant or a less productive geothermal well located in a high-enthalpy geothermal resource area. Average re-injection brine temperature from geothermal power plants ranges between 75°C and 55°C. The re-injection temperature can be optimized based on scaling problems and reservoir issues. This requires detailed reservoir simulation and geochemistry calculations. If temperature headroom exists in the re-injection brine, the temperature difference between the power plant brine outlet and re-injection wellhead limit may be a potential thermal energy source for MD desalination.

The following calculation was made to estimate this thermal energy potential. The USGS assessment indicates that the electric power generation potential from 248 identified medium- (90°C < T < 150°C) to high- (>150 °C) enthalpy geothermal systems is 9.05 GWe (Williams et al., 2008). Assuming an average inlet fluid temperature of 150°C, outlet brine temperature of 75°C, and thermal-to-electric conversion efficiency of 10% (Wendt et al., 2015), the required thermal energy is calculated as 90.5 GW<sub>th</sub>, with a required total flow rate around 1,000,000 metric tons per hour. Keeping the total flow rate unchanged (ignoring fluid losses) and selecting the theoretical lower limit of re-injection temperature of 55°C, the total heat potential that could be recovered from the flowing brine

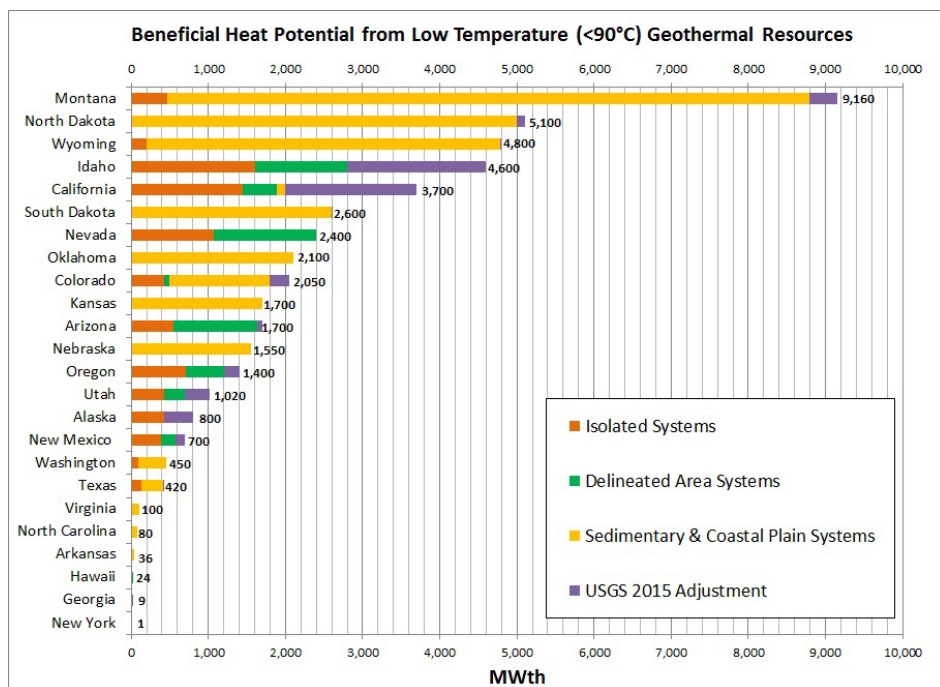

**Figure 5.** Beneficial geothermal heat potential by state originating from isolated, delineated and sedimentary systems (Original data source: Reed, 1983; Williams et al, 2015) Note: The USGS 2015 adjustment did not breakdown the additional heat potential by system category.

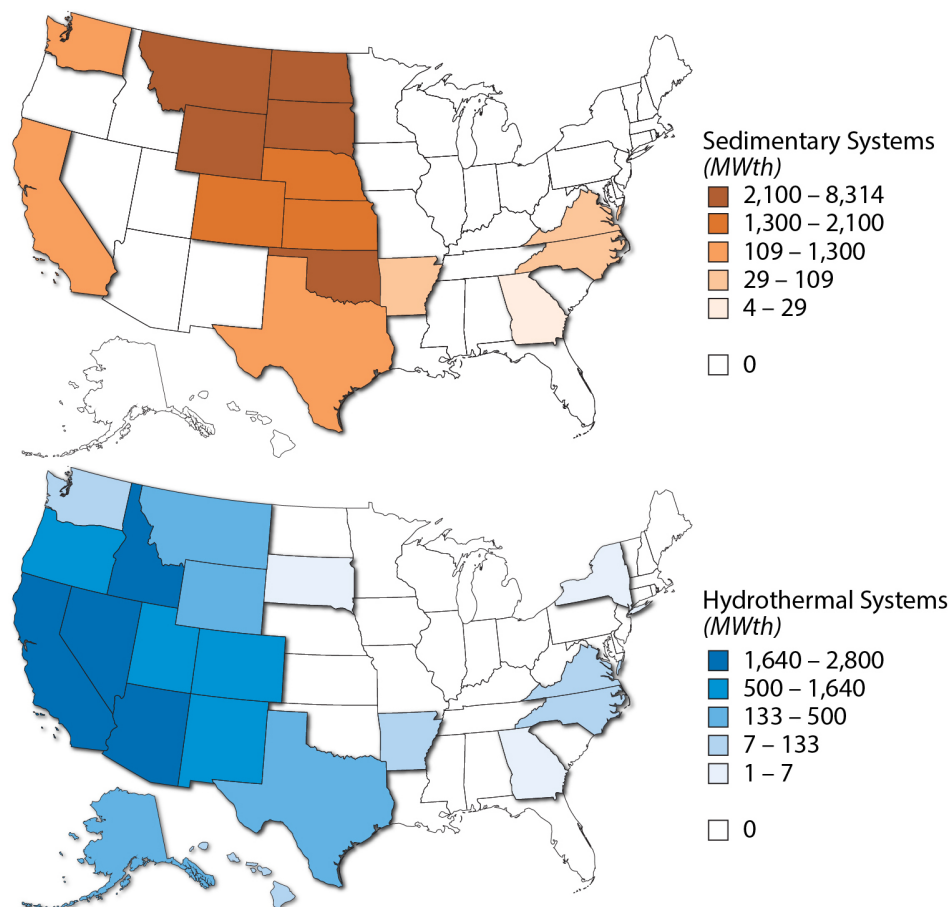

**Figure 6.** Distribution of estimated resource capacity of low-temperature hydrothermal and sedimentary & coastal plain systems by state (Data Source: Reed, 1983).

is estimated at 23 GW<sub>th</sub> for desalination (Figure 7). In addition to identified geothermal resources, mean estimated power production potential from undiscovered geothermal resources (*not including EGS potential*) is up to 30 GWe (Williams et al., 2008), suggesting a potential thermal energy around 300 GW<sub>th</sub> (77 GW<sub>th</sub> residual heat) based on the assumptions mentioned above.

The nameplate capacity of operating geothermal power plants in the United States is over 3,700 MWe; however, net electricity generation capacity is around 2,700 MWe (Matek, 2016). Thus, it also reveals the fact that there is already unused beneficial heat potential at operating geothermal power plants.

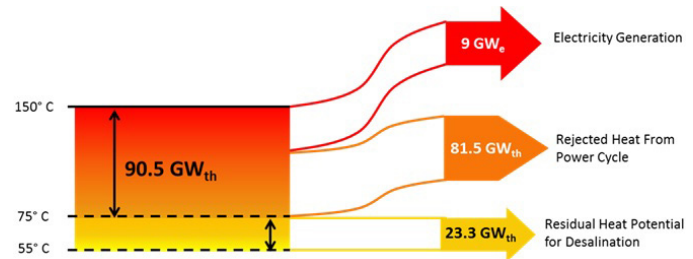

**Figure 7.** Residual thermal energy potential from identified medium- and high-enthalpy geothermal systems

#### 4. Data on the National Renewable Energy Laboratory's Geothermal Prospector

Data on the low-temperature geothermal resources used in this study are obtained from existing datasets and analyses from multiple data sources such as:

- Oregon Institute of Technology Geo Heat Center (OIT-GHC),
- USGS,
- Southern Methodist University (SMU),
- Association of American State Geologists (AASG)

These data are also publically available via the National Renewable Energy Laboratory's (NREL) Geothermal Prospector (<https://maps.nrel.gov/geothermal-prospector>). Low-temperature geothermal systems data are located under *Geothermal>Low Temperature Geothermal directory* and well data are located under *Infrastructure>Wells* directory. Additional details on the data are provided as metadata within Geothermal Prospector and listed below.

##### 4.1 OIT-GHC Data

The OIT-GHC database, which was originally released in 2004, has information on collocated resources, geothermal wells and springs. There are 6,874 wells and 1,847 springs in the database having information on the site name, county, depth, temperature, flow rate, and total dissolved solids (TDS) content. A collocated resource was defined by OIT-GHC as a geothermal resource with wells or springs with a temperature of 50°C and above and located within 5 miles (8 km) of a community (Boyd, 2008). The purpose of this compilation was to identify and encourage those communities to develop their geothermal resources. Historically, most of the communities that were identified have experienced some development of their geothermal resources. Collocated resource data are available in 16 states.

##### 4.2 USGS Circular 892 Data

The data obtained from USGS Circular 892 include available information on location, temperature, flow rate, acidity (pH) and TDS content of 2,071 wells and springs, which are representative of 1,168 low-temperature geothermal systems identified in 26 states. Data include minimum, maximum, and most likely values for temperature, area, and thickness of 148 identified delineated-area, low-temperature (<90°C) geothermal systems, and reservoir temperature estimates of 906 isolated low-temperature (<90°C) geothermal systems. Temperature values of isolated systems are estimated by chemical geothermometer calculations. Delineated-area systems data also include information on flow rate, temperature gradient, geologic environment, the geologic province and mean transmissivity.

##### 4.3 SMU and AASG Wells Data

The data obtained from SMU include bottom-hole temperatures from 119,493 observation points including geothermal wells, oil and gas wells, and water wells. These data have information on bottom-hole temperature and depth of wells. The data obtained from AASG include bottom-hole temperatures from mostly oil and gas boreholes which are recorded from log headers. These data have information from 524,657 wells including temperature measurements, depth and other information. Information presented in Geothermal Prospector was derived from data aggregated from the borehole temperature observations for all states. For each observation, the given well location was recorded and the best available well identified, temperature and depth were chosen. The data were then cleaned and converted to consistent units. The accuracy of the observation's location, name, temperature or depth was not assessed beyond that originally provided by AASG. In Figure 8, available well data in Geothermal Prospector are presented as a density map. This map is generated by using bottom

hole temperature measurements of more than 640,000 wells. For this analysis a search radius of 100 km is defined and the data are filtered based on temperature criteria. The high density – calculated as the number of wells divided by the search area (km<sup>2</sup>) – represents a maximum of 1.2 wells per km<sup>2</sup> and the lowest density represents a minimum of 0.0003 wells per km<sup>2</sup>.

### 5. Scenarios for Potential Heat Source From Geothermal Resources

We analyzed four different production scenarios to estimate levelized cost of heat (LCOH) for integration of MD desalination technology with low-grade geothermal heat. Our aim was to compare LCOH for these scenarios and select the most economic option for the thermal energy requirement of a desalination system. In the first scenario we selected residual heat from injection brine at a geothermal power plant as a potential heat source. In the second scenario, heat from existing under-utilized low-temperature wells was selected as the heat source. In the third scenario, we considered drilling new wells for identified low-temperature geothermal resources. In the last scenario, we investigated ground source heat pumps as an alternative heat source.



**Figure 8.** Density map of existing wells in the United States having bottom hole temperatures a) higher than 90°C, b) less than 90°C, and c) between 50°C and 90°C. (Data Source: AASG and SMU wells database).

#### 5.1 Scenario 1 - Existing Geothermal Power Plants

The first heat-source scenario assumes the use of excess or unused thermal energy from existing geothermal power plants. The typical re-injection temperature of outlet brine from a geothermal power plant is around 75°C, which is an excellent temperature match for MD desalination if a fraction of that heat can be extracted. This case scenario is the most cost-efficient way of accessing geothermal heat since all exploration and well-development efforts have already been done. Geothermal power plants may be water-cooled or air-cooled. In water cooled systems cooling tower blowdown water can also be used as source water for desalination. Average cooling-water requirements for geothermal power plants have been estimated as 2,000 gal/MWh (7.6 m<sup>3</sup>/MWh) of which 1,400 gal/MWh (5.3 m<sup>3</sup>/MWh) of water is evaporated

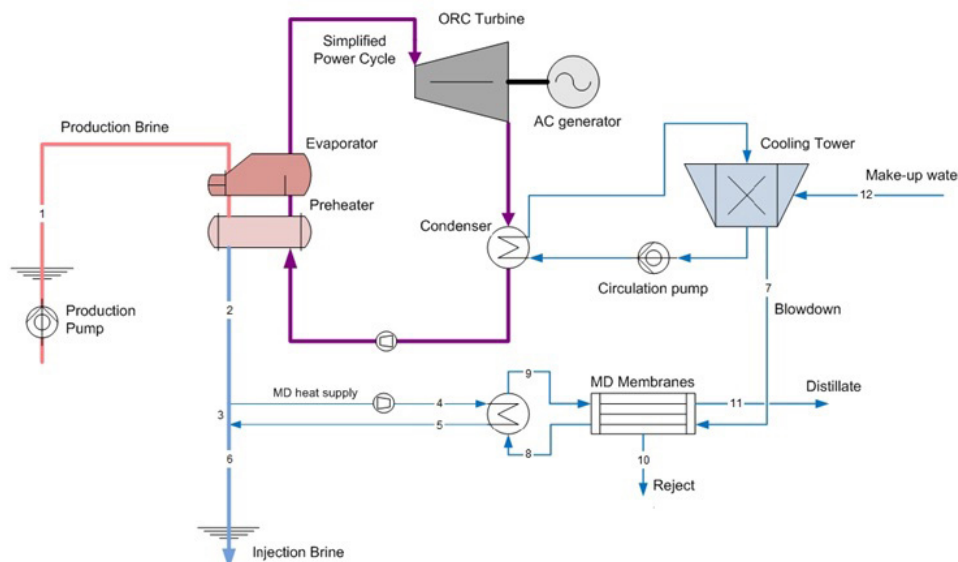

**Figure 9.** Conceptual process flow diagram of an MD system integrated with a water-cooled geothermal power plant.

and consumed during the cooling process and 600 gal/MWh (2.27 m<sup>3</sup> /MWh) is discharged as blowdown (Clark et al., 2010). If the blowdown flow volumes extended to all types of water-cooled power plants (including biomass, coal, geothermal, natural gas, nuclear, oil, and concentrating solar power) in the Western United States, the annual estimated volume is up to 60 billion gal/year (616,000 m<sup>3</sup>/day) (Turchi et al., 2015). Figure 9 demonstrates a possible process flow of an MD system integrated to a water-cooled geothermal power plant. In this integrated MD system, only heat is extracted from the geothermal re-injection brine. Thus, there is no consumptive usage of geothermal brine. The anticipated temperature drop in the injection brine stream is approximately 10-20°C, depending on plant conditions and relative brine-to-MD system flow rates. Because the injection brine will be cooled by the MD heat exchanger, detailed chemistry analysis and/or inhibitor optimization should be done to prevent scaling due to the temperature drop.

**5.2 Scenario 2 - Existing Under-Utilized or Abandoned Wells**

A second scenario is built on using existing under-utilized or abandoned wells. These wells may be geothermal wells, water wells or oil wells that meet the temperature criterion. These wells may belong to existing direct-use facilities such as district heating, space heating, industrial heating, or greenhouses. In this scenario the MD desalination plant may operate as a side facility using the heat from the system. No drilling costs are included, although well head equipment and pumping may be required.

**5.3 Scenario 3 - Drilling New Wells**

The third scenario assumes drilling new wells on undiscovered or under-utilized low-temperature geothermal systems. Drilling is the most expensive and highest risk stage of geothermal exploration. In this scenario, the total thermal energy cost of the MD system will increase due to the drilling cost. According to geothermal risk mitigation facility (GRMF), average drilling cost of a full-size geothermal production well is \$1200-1700/m (GRMF, 2015). The drilling cost estimates do not include well completion such as well head equipment, and pump. Smaller diameter, “slim-hole” wells may be appropriate for this application depending on the desired flow rate. Slim-hole wells are 40-60% cheaper than full-size production wells. Figure 10 presents typical well bore and casing diameter of a full-size well and slim-hole well. Average drilling cost of a slim hole well is \$600-900/m (GRMF, 2015). One disadvantage of slim-hole wells is the limited flow rate capacity due to the wellbore diameter (Hadgu et al., 1994).

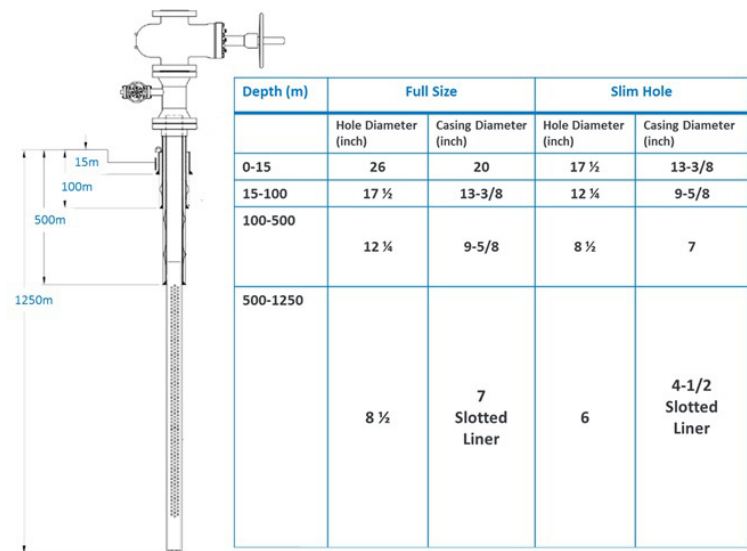

Figure 10. Drilling hole diameter and casing diameter comparison of a full-size geothermal production well and a slim-hole well.

**5.4 Scenario 4 - Ground Source Heat Pumps**

Ground source geothermal heat pumps were considered as an alternative solution to the thermal energy demand MD desalination system. In this case, the heat source is not limited to any hydrothermal low-temperature geothermal system. However, the efficiency of a geothermal heat pump system is directly related to the temperature difference between the circulating fluid in the loop and the temperature in the subsurface. This is implicit in the expression for thermal conductivity. The optimum subsurface temperature for a geothermal heat pump is 35-37°C. While MD is possible at such temperatures, the water vapor pressure and corresponding membrane flux is quite low. Also, consistent cooling at a 10-20°C lower temperature would be required. Such an application would require further analysis to determine regions where it may be viable.

**6. Levelized Cost of Heat Estimations From Geothermal Heat Sources**

The successful integration of MD with geothermal heat depends on that heat being available at very low cost. In this section we estimate the cost of geothermal heat and compare that to other energy sources, in particular natural gas. Table 1 outlines the estimated levelized cost of heat (LCOH) for different geothermal source scenarios described in Section 5. The LCOH is considered a convenient metric for estimating lifetime cost for geothermal direct-use ap-



plications. LCOH is loosely analogous to LCOE, which conventionally refers to electric energy. In its simplest form, LCOH is defined as:

$$LCOH = \frac{(Total\ Installed\ Project\ Cost) * (FCR) + (Annual\ O\ \&\ M)}{Annual\ thermal\ generation} \quad (2)$$

Total installed project cost includes capital cost of the total investment. The fixed charge rate (FCR) depends on a range of financial parameters that can have a significant influence on LCOH. NREL's System Advisor Model (SAM, version 2015-06-30) includes a procedure for estimating and using the FCR method, which is used in this study. Annual O&M includes operating costs in dollars per kilowatt-hour that vary with the amount of thermal energy the system generates. Annual thermal generation is the generated heat in kilowatt-hour thermal.

Kesime et al. (2013), estimated the cost of desalinated water for MD and MED systems assuming the cost of thermal energy at  $1.24\ \text{¢/kWh}_{th}$  (Figure 11). This is a relatively low value that corresponds to a natural gas price of about  $\$2/\text{MMBtu}$ . In order to hit a product water cost target of  $\$/\text{m}^3$ , the thermal energy cost would have to decrease to  $0.4\ \text{¢/kWh}_{th}$ . To hit a cost of  $\$1.5/\text{m}^3$  the required energy cost is  $0.9\ \text{¢/kWh}_{th}$ . For comparison, product water from the new Carlsbad Desalination Project, a large RO plant in southern California, is reported to cost about  $\$1.7/\text{m}^3$  (SDCWA, 2015).

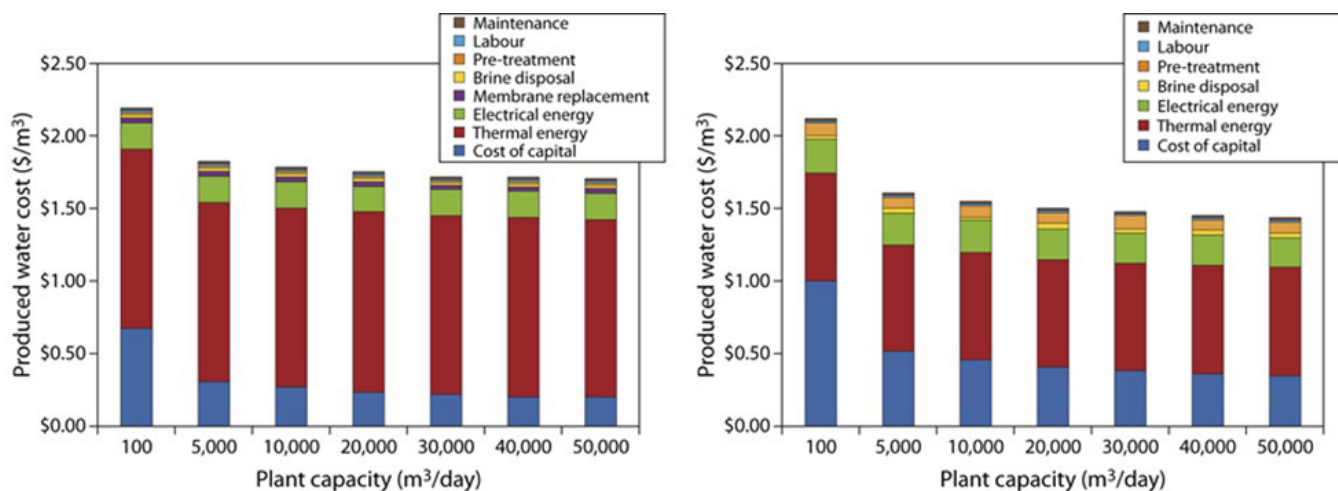

**Figure 11.** Water cost by cost category for MD (left) and MED (right) systems. For MD, capital expenses (CAPEX) is low and overall cost is dominated by the cost of thermal energy (Kesime et al. 2013). Consequently, low-cost geothermal energy could significantly lower the cost of water from an MD process.

In this study, three scenarios have been examined for geothermal heat production: 1) siphoning heat off an existing geothermal power plant prior to reinjection, 2) utilizing existing production and injection wells that are not fully completed and maintained, and 3) drilling new production and injection wells, either full size or slim-hole, in a proven resource areas. Geothermal field characteristics, estimated CAPEX and operational expenses (OPEX) cost, and financial assumptions for LCOH calculations are summarized in Table 1. LCOH is estimated for the different cases using a set of financial assumptions taken from SAM's default values. The resulting LCOH ranges from  $0.28\ \text{¢/kWh}_{th}$  to  $1.05\ \text{¢/kWh}_{th}$  ( $\$0.8$  to  $\$3.1/\text{MMBtu}$ ).

The cost of thermal energy from geothermal resources is highly dependent on the cost of drilling, resource potential, and fluid enthalpy from production wells. LCOH from new wells (full-size or slim-hole) is estimated to be approximately  $1.0\ \text{¢/kWh}_{th}$  (Table 1). The relatively high LCOH is related to the drilling cost. When an existing geothermal well is used the LCOH can be lowered down to about  $0.51\ \text{¢/kWh}_{th}$  (Table 1). The lowest LCOH can be achieved by accessing unused low-temperature heat from geothermal power plant re-injection brine which results in a cost of  $0.28\ \text{¢/kWh}_{th}$  ( $\$0.8\ \text{MMBtu}$ ).

In this study, drilling new wells for desalination is estimated to be prohibitively expensive as a source of low-temperature heat. Furthermore, it is likely that the WACC for new wells will be higher than that for use of existing wells due to the greater risk in exploration and drilling. Completing and using existing, under-utilized wells results in estimated thermal energy cost of  $0.5\ \text{¢/kWh}_{th}$ , which will result in water cost between  $\$/\text{m}^3$  and  $\$/\text{m}^3$  based on Kesime's analysis.

**Table 1.** Summary of LCOH estimates for different production scenarios.

Geothermal Field Characteristics	Units	New Wells		Existing Wells	Existing Power Plant Re-Injection Brine
		Full-Size	Slim-Hole		
Production Temperature	°C	90	90	90	75
Re-Injection Temperature	°C	55	55	55	55
Average Temperature Gradient	°C/100m	6	6	NA	NA
Drilling Depth	m	1250	1250	NA	NA
Flow Rate/well	L/s	89	40	89	NA
Total Flow Rate	L/s	89	40	89	238
Thermal Energy Capacity	MWt	13.00	5.80	13.00	19.9
Capacity Factor	%	90%	90%	90%	90%
Annual Operational Hours	h	7884	7884	7884	7884
Annual Production	kWht/yr	102,492,000	45,727,200	102,492,000	156,891,600
# Production Wells		1	1	1	NA
# Re-Injection Wells		1	1	1	NA
<b>CAPEX</b>					
Development Cost	\$	500,000	150,000	0	0
Drilling Cost	\$/well	2,112,500	967,500	0	0
Total Drilling Cost	\$	4,225,000	1,935,000	0	0
Geothermal Equipment Cost**	\$	300,000	200,000	200,000	250,000
Pump Cost	\$	500,000	250,000	250,000	50,000
Piping Cost*	\$	300,000	300,000	300,000	60,000
<b>Total</b>	<b>\$</b>	<b>5,825,000</b>	<b>2,835,000</b>	<b>750,000</b>	<b>360,000</b>
<b>OPEX</b>					
Pumping Cost (Electricity)*	\$/yr	211,883	42,377	211,883	105,941
Inhibitor Cost	\$/yr	50,000	10,000	50,000	100,000
Labor Cost	\$/yr	100,000	100,000	100,000	100,000
Re-Injection Cost	\$/yr	127,130	16,951	84,753	100,000
<b>Total</b>	<b>\$/yr</b>	<b>489,012</b>	<b>169,327</b>	<b>446,636</b>	<b>405,941</b>
<b>Financial Assumptions</b>					
Weighted average cost of capital (WACC)	%	6.2%	6.2%	6.2%	6.2%
Project life	years	20	20	20	20
Calculated fixed charge rate	-	0.101	0.101	0.101	0.101
<b>LCOH</b>	<b>¢/kWh<sub>th</sub></b>	<b>1.05</b>	<b>1.00</b>	<b>0.51</b>	<b>0.28</b>
<b>LCOH</b>	<b>\$/MMBtu</b>	<b>3.1</b>	<b>2.9</b>	<b>1.5</b>	<b>0.8</b>

\* *Major assumptions:* (i) 1000 m spacing between production and re-injection well, (ii) unit cost of insulated pipe \$300/m, (iii) 250 kW average electricity consumption for a submersible pump to produce 89 L/s flow rate, and (iv) 2015 commercial U.S. average electricity price 10.7 ¢/kWh

\*\* *Includes well completion cost, well head equipment, separators, heat exchangers, etc.*

energy, a low operating cost. Based on literature data, product-water cost could be less than \$1/m<sup>3</sup> if thermal energy is inexpensive. Furthermore, the MD technology is suited for small-scale installations, and although small plant capacity increases the water cost, the scale is ideally suited for application in rural areas with modest-size geothermal resources.

Four different scenarios were explored for a source of geothermal heat: (1) using residual heat from injection brine at a geothermal power plant, (2) tapping under-utilized low-temperature wells, (3) drilling new wells for low-temperature resources, and (4) using geothermal heat pumps. Cases that required drilling dedicated wells resulted in thermal energy costs exceeding 1 ¢/kWh<sub>th</sub> (\$3/MMBTU) and were rejected as too expensive. The option of using geothermal heat pumps was given only a cursory review because the maximum temperature of such systems (~40°C) is below that desired for an

The cheapest source of thermal energy is excess heat coming from the outlet brine of geothermal power plants. In this case capital costs include only a booster pump and interconnection piping, while operational costs include labor, re-injection pumping and chemical control (inhibitors). Inhibitor optimization to prevent scaling, re-injection strategy for long-term production and the potential effect of reinjecting cooler brine on the reservoir thermal breakthrough should be investigated carefully in the case of thermal energy extraction from geothermal power plant outlet brine.

## 7. Discussion and Conclusions

The examination of different desalination technologies led to the selection of MD for pairing with geothermal energy. MD operates at near-ambient pressure and temperatures less than about 90°C using hydrophobic membranes. The thermal-energy demands of MD are higher than conventional MED, but this is offset by an ability to run at lower temperatures and a low capital cost. Consequently, a geothermal MD system could offer a low capital cost and, if paired with low-cost geothermal

MD system. Tapping into existing, but under-utilized low-temperature wells (scenario 2) resulted in borderline costs that might be viable in certain cases. Lastly, using residual heat from injection brine was identified as the lowest-cost option, given situations where the injection brine temperature can be lowered without causing scaling or resource life concerns. Under these conditions, thermal energy cost was estimated at \$0.8/MMBTU and resulting MD water cost at less than \$1/m<sup>3</sup>.

The economics of desalination remain challenging regardless of technology. Consequently, desalination is best applied where high-quality product water is valued and the impaired source water requires treatment for disposal. For example, desalination could reduce the volume of water that needs to be treated and/or injected into deep disposal wells. Such a situation provides two sources of “revenue” for the process—valuable product water and avoided treatment costs. The deployment of desalination as a hedge against future water scarcity, despite its relative cost, is sometimes listed as an additional supporting factor, especially in areas with limited water availability. These “dual-revenue” conditions may exist for produced and flowback water from oil and gas operations, industrial wastewater, cooling tower blowdown, and locations where zero-water discharge is required or preferred. Thermal desalination processes can tolerate water of much higher TDS than RO systems, so locations striving for zero-liquid discharge or wishing to extract additional water from RO reject brine also would be amenable to geothermal desalination.

Based on these considerations, the treatment of cooling-tower blowdown water has been selected as a potential application for geothermal MD, and a test site has been identified. In year two of a project begun in 2016 the NREL-led team will access cooling-tower blowdown water at a geothermal power plant and use residual geothermal heat from the injection brine in a small-scale MD process. While this is a relatively small market opportunity, it provides a useful proving ground for the MD technology. Project objectives include the following:

- Demonstrate the integration of MD with geothermal energy,
- Develop a performance model and validate membrane flux estimates with commercial-scale modules under field conditions at different operating conditions,
- Demonstrate life and performance of the membranes and membrane modules,
- Test and evaluate anti-scaling and/or antifouling coatings applied to commercial membranes, and
- Estimate cost of product water based on membrane performance and a sensitivity analysis to the cost of geothermal heat.
- Describe and quantify applications beneficial to the geothermal industry.

Based on low-temperature geothermal resource assessment estimates, total resource capacity for identified hydrothermal systems is about 13,000 MW<sub>th</sub>. At present, only a small portion of these resources are in use for direct-heat applications. When the residual beneficial heat from identified medium- and high-temperature geothermal resources (23,300 MW<sub>th</sub>) is added to the total resources, available thermal energy potential reaches 36,300 MW<sub>th</sub> for utilization of heat on MD desalination. This potential would increase to higher levels when sedimentary low-temperature systems, residual heat from undiscovered medium- to high-temperature geothermal systems and heat potential from existing oil and gas wells are added. Assuming reasonable desalination efficiencies (defined as a gained output ratio of 1 to 5, the amount of water that could theoretically be produced using the thermal energy potential is 1.4 to 7 million cubic meters per day.

## Acknowledgements

This work was supported by the U.S. Department of Energy, Office of Energy Efficiency and Renewable Energy (EERE), Geothermal Technologies Office (GTO) under Contract No. DE-AC36-08-GO28308 with the National Renewable Energy Laboratory (NREL). The authors wish to thank reviewers for their comments and suggestions including, Emily Newes and Ann Brennan from NREL, and Patrick Dobson from Lawrence Berkeley National Laboratory (LBNL). The authors also thank to Billy Roberts from NREL for his help on GIS analysis and maps. All errors and omissions are the responsibility of the authors.

## References

- Boyd, T., 2008, “Communities with Geothermal Resource Potential” Geo-Heat Center, Oregon Institute of Technology
- Boyd T., Sifford A., Lund J.W. 2015, “The United States of America Country Update 2015”, World Geothermal Congress, Melbourne, Australia.
- Clark, C., Harto, C. B., Sullivan J. L., and Wang, M. Q., 2010, “Water Use in Development and Operation of Geothermal Power Plants”, Argonne National Laboratory
- Famiglietti J. S. and Rodell M., 2013, “Water in Balance,” *Science*, vol. 340, no. 6138, pp. 1300-1301

- Grant M. A., 2015, Resource Assessment, a Review, with Reference to the Australian Code, Proceedings World Geothermal Congress 2015, Melbourne, Australia, 19-25 April 2015
- GRMF, 2015, Anticipated Well Cost Guidelines, Geothermal Risk Mitigation Facility, Third Edition.
- Hadgu T., Zimmerman R. W., and Bodvarsson G. S., 1994, Theoretical Studies of Flowrates From Slimholes and Production-Size Geothermal wells, 19th Workshop on Geothermal Reservoir Engineering, Stanford University, California
- Kesime U. K., Milne, N., Aral H., Cheng C. Y. and Duke M., 2013, “Economic analysis of desalination technologies in the context of carbon pricing, and opportunities for membrane distillation”, *Desalination*, vol. 323, pp. 66-74
- Lund J. W., 2012, “Direct Heat Utilization of Geothermal Energy” in *Comprehensive Renewable Energy*, Elsevier.
- Matek, B., 2016, Annual U.S. & Global Geothermal Power Production Report, Geothermal Energy Association, 36 p
- Muffler, L. J. P., 1979, Assessment of Geothermal Resources in the United States-1978, USGS Circular 790, (Edited by Department of Interior: United States Geological Survey).
- NDMC, 2016, National Drought Monitoring Center, <http://droughtmonitor.unl.edu/>
- Porro C., Esposito A., Augustine C., Roberts B., 2012, An Estimate of the Geothermal Energy Resource in the Major Sedimentary Basins in the United States, *GRC Transactions*, Vol. 36, p.1359-1370
- Reed M. J., 1983, Assessment of Low Temperature Geothermal Resources of the United States – 1982, USGS Circular 892, (Edited by Department of Interior: United States Geological Survey).
- SDCWA, San Diego County Water Authority, “Seawater Desalination: Carlsbad Desalination Project,” [sdcwa.org](http://sdcwa.org), San Diego, California, Factsheet March 2015.
- Turchi, C.S., Akar S., Cath T., Vanneste J., and Geza M., 2015, “Use of Low-Temperature Geothermal Energy for Desalination in the Western United States,” NREL Technical Report NREL/TP-5500-65277.
- OIT-GHC, 1996, Oregon Institute of Technology Geo-Heat Center, Geothermal Resource Assessment Map for Direct Heat Applications
- Wendt D., Mines G., Turchi C., and Zhu G., 2015, “Geothermal Risk Reduction via Geothermal/Solar Hybrid Power Plants: Final Report,” Idaho National Laboratory, INL/EXT-15-37307
- Williams C.F., DeAngelo J., and Reed M. J., 2015, Revisiting the Assessment of Geothermal Resources <90 °C in the United States, *GRC Transactions*, v.38, p93-98
- Williams C.F., Reed M. J., Mariner R. H., DeAngelo J., Galanis, S.P. Jr., 2008, Assessment of Moderate and High Temperature Geothermal Resources of the United States, USGS Fact Sheet 2008-3082, 4p.
- Ziolkowska J., 2015 “Is Desalination Affordable?—Regional Cost,” *Water Resource Management*, vol. 29, pp. 1385-1397