

NOTICE CONCERNING COPYRIGHT RESTRICTIONS

This document may contain copyrighted materials. These materials have been made available for use in research, teaching, and private study, but may not be used for any commercial purpose. Users may not otherwise copy, reproduce, retransmit, distribute, publish, commercially exploit or otherwise transfer any material.

The copyright law of the United States (Title 17, United States Code) governs the making of photocopies or other reproductions of copyrighted material.

Under certain conditions specified in the law, libraries and archives are authorized to furnish a photocopy or other reproduction. One of these specific conditions is that the photocopy or reproduction is not to be "used for any purpose other than private study, scholarship, or research." If a user makes a request for, or later uses, a photocopy or reproduction for purposes in excess of "fair use," that user may be liable for copyright infringement.

This institution reserves the right to refuse to accept a copying order if, in its judgment, fulfillment of the order would involve violation of copyright law.

A SIMPLE, INEXPENSIVE DOWNHOLE GEOTHERMAL FLUID SAMPLER *

Donald M. Thomas

Hawaii Institute of Geophysics
University of Hawaii
Honolulu, Hawaii 96822

ABSTRACT

Several commercially available downhole water samplers have been used in a high temperature geothermal well in Hawaii; none have been able to withstand the temperature-pressure conditions found at the bottom of the hole (358°C, 150 kg/cm²). A sampler has been designed which is able to provide reliable samples and which is inexpensive to fabricate and easy to service in the field.

INTRODUCTION

During research conducted on the geothermal well on the island of Hawaii (HGP-A), considerable difficulty was experienced in sampling of downhole fluids. The source of nearly all the problems encountered was the inability of most commercially available samplers to withstand the temperature and pressure conditions near the bottom of HGP-A (358°C, 150 kg/cm²).

DESIGN

A new downhole fluid sampler has been designed which we feel has overcome most of the initially encountered difficulties. The body and all critical attachments are of stainless steel; pressure tight gaskets are also of stainless steel or of teflon impregnated asbestos. Sample entry into the bottle is through a capped stainless steel tube which is attached with a swage fitting to the inlet of the check valve. Both the check valve and sample exit valves are mounted outside the pressure tight sample bottle to allow for simple and rapid field servicing. The check and sample exit valves are both commercially available (Autoclave Engineers UB4400 and Marsh Valve FFG 1/8" NPT valve stem and packing) and can be easily and inexpensively replaced.

OPERATION

The sampler is opened downhole by releasing a "go-devil" from the surface which impacts onto a puncture mechanism at the top of the sampler. The "go-devil" release is through a pressure tight seal allowing sampling to take place when the well head is under pressure. Sample exit is through a valve at the bottom of the sampler and can be done under pressure by attachment of a mercury displacement pump at the inlet of the check valve.

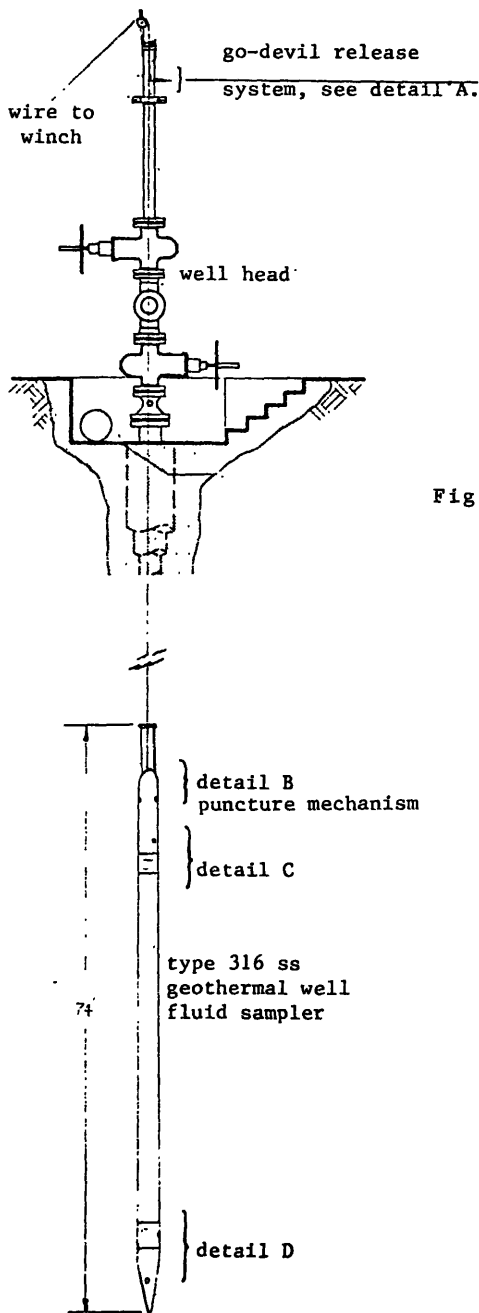

Fig. 1

*Hawaii Institute of Geophysics Contribution No. 989

Thomas

Although this sampler incorporates no major technological breakthroughs in the design, its ease of operation and simplicity of fabrication and servicing renders it superior to most geothermal samplers presently on the market. Detailed design drawings are available on request from Hawaii Institute of Geophysics.

ACKNOWLEDGMENTS

I wish to thank Mr. J. Johenko for providing design drawings and for assistance in the design and testing of this sampler.

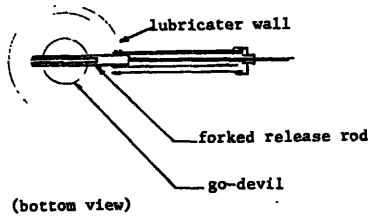
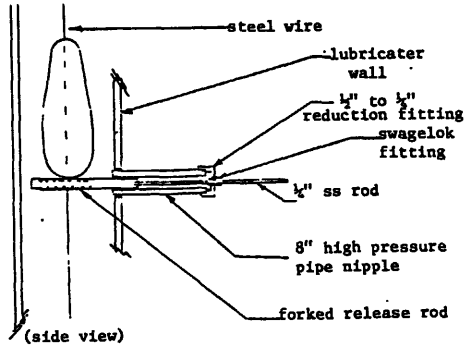

Detail A

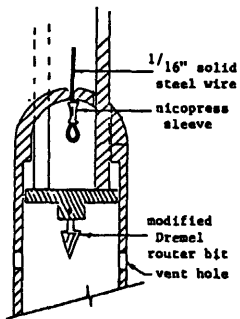

Detail B

